

DC POWERED HYDRAULIC SCISSOR LIFT CART - CART-1000-2040-DC

APPROX WEIGHT: 344.72 lbs.
 DOES NOT INCLUDE WEIGHT OF POWER OR PACKAGING!!!

*** ANY ADDITIONS, DELETIONS, OR OMISSIONS MUST BE CORRECTED ON THIS DRAWING AS THIS DRAWING WILL BE CONSIDERED ALL INCLUSIVE ***
 ALL GRAPHICS PROVIDED ARE FOR REFERENCE ONLY. IF CERTAIN DIMENSIONS ARE CRITICAL PLEASE VERIFY THOSE DIMENSIONS WITH YOUR SALESPERSON

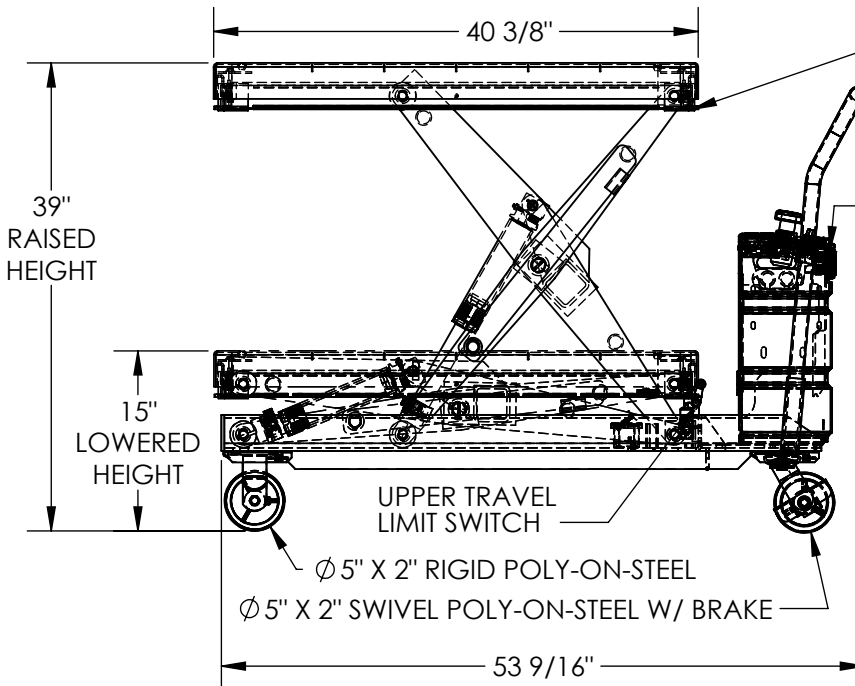

ELECTRIC TOEGUARDS
 (STOPS TABLE FROM
 LOWERING IF BUMPED)
 MEETS OSHA 1910.212

STANDARD:
 12V DC HYDRAULIC POWER UNIT
 RAISED AND LOWERED BUTTONS ARE ON
 TOP OF POWER UNIT
 WITH ON BOARD CHARGER
 AND HAND CONTROL

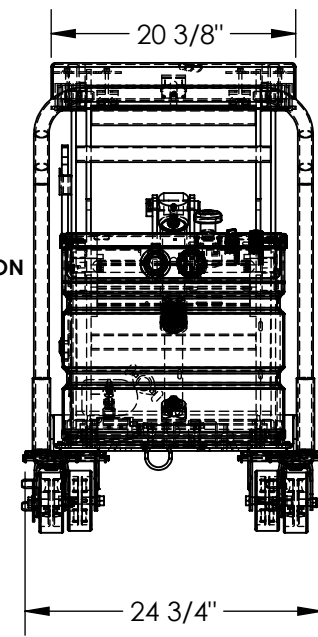

DECK TOLERANCE $\pm 1/2$ "
 TABLE HEIGHT TOLERANCES $\pm 1/2$ "
 DECK FLATNESS $\pm 1/4$ "

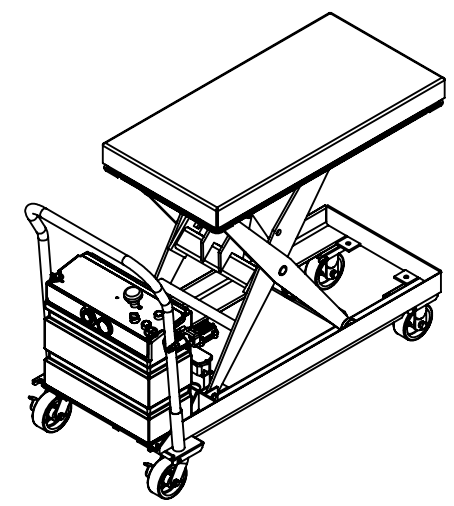

STANDARD FEATURES

- MODEL NUMBER IS CART-1000-2040-DC
- DECK WIDTH IS 20 3/8"
- DECK LENGTH IS 40 3/8"
- RAISED HEIGHT IS 39"
- LOWERED HEIGHT IS 15"
- Ø 5" X 2" RIGID POLY-ON-STEEL CASTERS
- Ø 5" X 2" SWIVEL POLY-ON-STEEL W/ BRAKE CASTERS
- TABLE CAPACITY (EVENLY DISTRIBUTED)
- MAX CAPACITY IS 1,000 LBS
- CONTROL IS HANDHELD 2 BUTTON, NEMA 4 PENDANT WITH MINIMUM 8' USABLE COIL CORD
- SAFETY MAINTENANCE PROPS, DISPLACEMENT STYLE CYLINDERS INSTALLED ROD DOWN
- EMERGENCY SAFETY STOP HYDRAULIC FUSES
- UPPER TRAVEL LIMIT SWITCH
- ELECTRIC PINCH POINT GUARD
- DURABLE LIQUID PAINT BLUE FINISH

SPECIAL FEATURES

NONE

DIMENSION TOLERANCE $\pm 1/4$ "

APPROVAL

I, THE UNDERSIGNED, AGREE THAT THE PRODUCT AS REPRESENTED SATISFIES DESIGN AND DIMENSION REQUIREMENTS. I ALSO ACKNOWLEDGE MY DUTY TO CONFIRM PRODUCT AND INSTALLATION COMPLIANCE WITH ALL APPLICABLE FEDERAL, STATE AND LOCAL REGULATIONS AND STANDARDS.

UNITS REQUIRING APPROVAL DRAWINGS OR MODIFIED ARE NON-RETURNABLE

As drawn As marked

Signed: _____ Date: _____

Printed Name: _____

LEAD TIME WILL START UPON RECEIPT OF SIGNED APPROVAL DRAWING

DISTRIBUTOR'S NAME:		P.O.#
VESTIL MANUFACTURING		X
DRAWN BY: KC	DATE: 3/14/16	W.O.#
REFERENCE: X	SCALE: 1:16	X
QUOTED LEAD TIME: X	QUOTE #	SALES: X
	X	FILE NAME:
		01-007-067